

spool type	diameter		boards		bores $\varnothing$			distance between D and C	winding width	overall width	threaded rod
	flange	core	flange thickness	core bars groove width	central bore	drive hole	cable passage				
	$d_1$	$d_2$	K	G	C	D	F	I	$L_2$	$L_1$	M/St.
4	400	150	20	14	56	20	-	85	405	450	6/3
5	500	150	20	14	56	20	-	85	405	450	6/3
6	600	250	36	22	85	30	30	100	400	480	10/4
7	710	355	36	22	85	30	40	100	400	480	10/4
8	800	400	36	22	85	40	40	100	400	480	10/4
9	900	450	36	22	85	50	50	160	560	650	10/4
10	1000	500	36	22	85	50	50	160	560	650	10/4
12	1250	630	44	22	85	65	60	160	710	800	12/4
14	1400	700	64	27	85	65	65	300	710	850	16/4
15	1500	800	64	27	85	65	65	300	710	850	16/4
16	1600	800	64	27	85	65	80	300	900	1040	16/4
18	1800	1000	64	32	100	65	80	300	900	1080	16/6
20	2000	1200	76	32	100	65	100	300	900	1100	16/6
22	2200	1200	90	38	125	65	120	300	1100	1340	20/8
24	2400	1400	90	38	125	65	130	600	1210	1450	20/8
25	2500	1600	100	38	125	65	130	600	1250	1510	20/8

Optionally with:  $K_1$  - middle chaplet ·  $K_2$  - side chaplet ·  $K_3$  - inner cable passage · a - metal plate with socket, g - metal plate thickness

All dimensions are in millimeter [mm].

## WOODEN CABLE DRUMS

As an experienced manufacturer of innovative wood products, Steinnagel develops valuable and customised drums made of solid and weather-resistant wood. Our drums offer the perfect solution for the packaging, stocking and transportation of cables, steel ropes, plastic tubes etc.

Our consistently client-oriented working method enables us to develop and produce wooden cable drums according to the needs and demands of our customers.

Depending on the customers' preference, we provide our drums with special surface cuttings, company logos, continuous numbers and lacquerings. We also provide a special cable management system, which

enables you to set the cable into the outside of the flange and to fix it with plastic clips to avoid distortions and damages during the transport. While our drums are available in various versions, they all provide the best possible protection of the products, for the core and the flange are always made of planed blanks, which prevents damages during the unwinding. To avoid further storage costs and allow a quick onward transport, our drums are always heat-treated.

# wooden cable drums (one way)

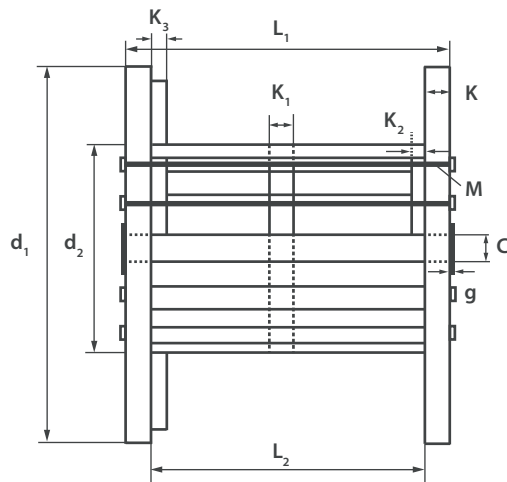
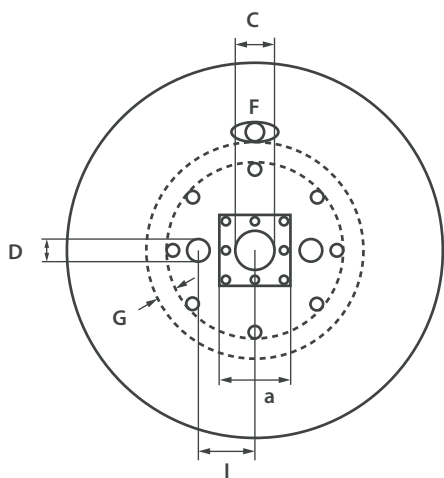

spool type	diameter		boards		bores $\varnothing$			distance between D and C	winding width	overall width	threaded rod
	flange	core	flange thickness	core bars groove width	central bore	drive hole	cable passage				
	$d_1$	$d_2$	K	G	C	D	F				
4	400	150	20	14	56	20	-	85	405	450	6/3
5	500	150	20	14	56	20	-	85	405	450	6/3
6	600	250	30	22	56	30	40	80	360	420	10/3
7	710	355	30	22	85	30	40	100	400	460	10/4
8	800	400	30	22	85	40	40	100	400	460	10/4
9	900	450	30	22	85	50	40	160	560	620	10/4
10	1000	500	36	22	85	50	50	160	560	632	10/4
12	1200	630	44	22	85	65	60	160	710	798	12/4
14	1400	700	64	27	85	65	60	300	710	838	16/4
16	1600	800	64	27	85	65	60	300	900	1028	16/4
18	1800	1000	64	38	100	65	80	300	900	1028	16/6
20	2000	1200	76	38	100	65	120	300	900	1052	16/6
22	2200	1200	76	38	125	65	120	300	1100	1252	20/8
24	2400	1400	76	38	125	65	120	300	1210	1362	20/8
25	2500	1600	76	38	125	65	120	600	1250	1402	20/8

Optionally with:  $K_1$  - middle chaplet ·  $K_2$  - side chaplet ·  $K_3$  - inner cable passage · a - metal plate with socket, g - metal plate thickness

All dimensions are in millimeter [mm].



[info@steinnagel.com](mailto:info@steinnagel.com)